

JK Mold Design

STREAMLINING THE MOLD DESIGN AND PRODUCTION PROCESS WITH SOLIDWORKS

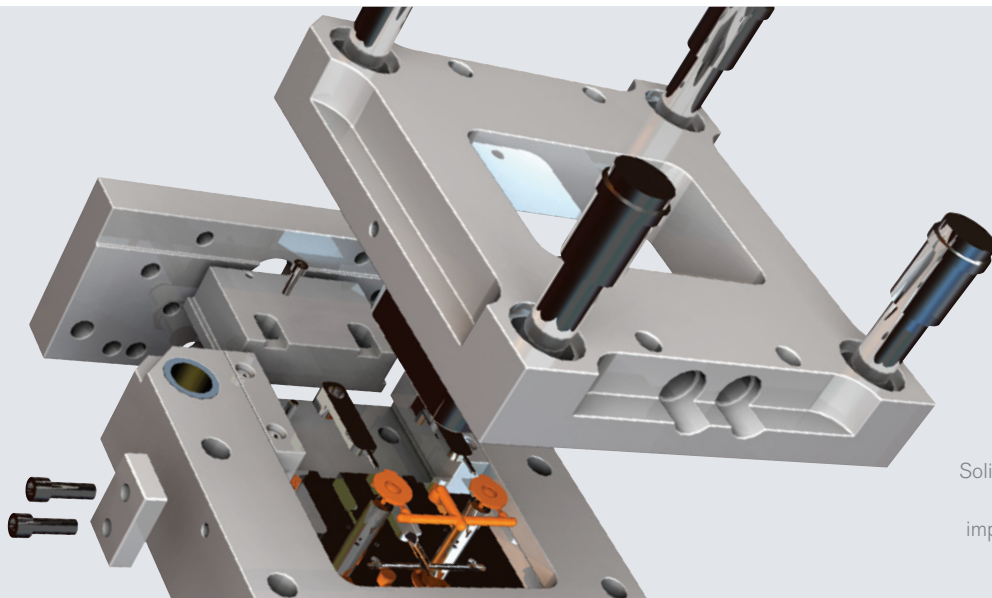

SolidWorks software streamlines the mold design and production process for JK Mold Design by providing flexibility for data import and export, including tools for interrogating mold designs, and improving design communications with customers.

- Reduced mold design cycle by 50 percent
- Increased ability to import/export various data formats
- Improved design communications with customers
- Enhanced mold analysis capabilities

JK Mold Design is a leading provider of high-end, complex mold designs for plastic injection-molded parts and aluminum and zinc die casting. Until the late 1990s, the contract design firm used the CADKEY® 2D design package to create engineering drawings for mold designs that customers use to manufacture products and components. According to John Kreuzberger, owner of JK Mold Design, 2D tools were adequate until he began receiving a variety of 3D design data. He discovered he was spending an inordinate amount of time rebuilding models in 2D, and started landing projects requiring increasingly complex mold designs.

"I encountered problems with importing and exporting other CAD data formats," Kreuzberger explains. "In addition to the huge time waste associated with redrawing models in 2D, you run the risk of making mistakes by misinterpreting the model. My customers often could not import the 2D mold data I produced and would have to recreate a 3D model from my mold drawings, which created additional work and represented another opportunity for error." Kreuzberger says he realized he needed a versatile 3D CAD package that could import and export data from a variety of design systems in order to continue to provide the level of quality and service his customers had come to expect.

After evaluating several solid modeling packages, Kreuzberger selected the SolidWorks® 3D CAD system because it was the most versatile 3D package for handling diverse CAD data, provided access to a robust set of add-on mold design and production applications, included inherent mold design interrogation capabilities, produced engineering drawings and detail views automatically, and represented the best value for the price. Since implementing SolidWorks software, JK Mold Design has reduced its mold design cycle by 50 percent.

"Working in 3D with SolidWorks, I have reinvented myself as a mold designer and now provide my customers with a range of capabilities I simply could not offer before," Kreuzberger says.

“SolidWorks is a really powerful tool that enables me to work directly from imported customer models.”

John Kreutzberger, Owner

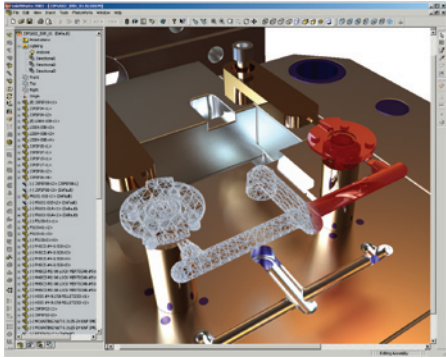

JK Mold Design uses SolidWorks software to accelerate the mold production process by supporting automatic tool path creation through one of several fully integrated CAM applications, such as SURFCAM.

Varied data in, usable data out

Whether working with geometry from 3D CAD systems, IGES files, or 2D design data, JK Mold Design has dramatically improved its data handling and manipulation capabilities with SolidWorks software. “SolidWorks is a really powerful tool that enables me to work directly from imported customer models,” Kreutzberger notes.

“But importing design data is just part of the equation,” he adds. “Providing my customers with a mold design in a readable, usable format is an even greater benefit. I no longer ask customers what file format they can read. I ask them what they prefer. I cannot remember a single instance in which a customer required a file format I could not provide with SolidWorks.”

Fully interrogating mold designs

Since implementing SolidWorks software in 1998, JK Mold Design has benefited from continual development of mold-specific functionality, such as parting line, draft, and undercut analysis tools, to fully interrogate mold designs of increasing complexity. Kreutzberger also uses MoldWorks® software, a SolidWorks Partner application from R&B Ltd., to automate the creation of mold components, holes, and endplates.

“The tools that SolidWorks has added over the past few years are very helpful for resolving moldability issues,” Kreutzberger notes. “I like to use the cavity function in SolidWorks to do my core cavity splits, using the shrinkage capability to scale parts. Once I have a model of the mold, I can either send a SolidWorks model or an eDrawings® file to the customer to show how I have resolved a moldability issue, such as sufficient draft.

“It’s much easier for me to communicate issues to customers and resolve them quickly with a 3D model and these tools,” he adds. “I am also seeing more and more SolidWorks models, which further streamlines the mold design process.”

Accelerating mold creation

In addition to improving data handling and mold analysis capabilities, the transition to SolidWorks is enabling JK Mold Design to help its customers accelerate the mold production process. Using a SolidWorks model, the company’s clients can automatically create tooling paths for CNC machines to produce molds using one of several integrated computer-aided manufacturing (CAM) applications, such as SURFCAM® software.

“I have received very good feedback from customers who use SolidWorks models for CNC machining,” Kreutzberger stresses. “SolidWorks software streamlines the mold design process on my end, improves my ability to communicate with clients efficiently, and increases productivity in manufacturing on the customer end. That’s a real positive for me in an increasingly competitive global market.”



Dassault Systèmes SolidWorks Corp.
300 Baker Avenue
Concord, MA 01742 USA
Phone: 1 800 693 9000
Outside the US: +1 978 371 5011
Email: info@solidworks.com
www.solidworks.com

JK Mold Design

JK Mold Design
170 Southgate Road
Sacramento, CA 95815
Phone: +1 916 813 9764
www.jkmolddesign.com